



IPH HYDRAULICS

(formerly Indian Pneumatic
& Hydraulic Co) 

HYDRAULIC CYLINDER

ISO 6020 / 1

MEDIUM SERIES

160 Kg/cm².



www.iphindia.in

With experience and expertise for more than thirty years in manufacturing cylinders – both hydraulic and pneumatic, IPH is one of the leading names in the field in India, today.

We manufacture cylinders for Machine Tools, Steel Mills, Construction Machinery, Presses and all automatic operations.

Our specialties:

- Large bore cylinders
- Long stroke cylinders
- Cylinders with Reed Switches
- Cylinders with Proximity Switches
- Telescopic Cylinders – Single/Double acting
- Tailor made cylinders, as per customer requirements

LOAD CALCULATION CHART						
Diameter in mm		Area in cm ²			Theoretical Forces in Ton	
Bore Dia	Rod Dia	Piston Area	Rod Area	Annular Area	Pushing force at 160Bar	Pulling force at 160Bar
25	16	4.9	2.0	2.9	0.8	0.5
	18		2.5	2.4		0.4
32	18	8.0	2.5	5.5	1.3	0.9
	22		3.8	4.2		0.7
40	22	12.6	3.8	8.8	2.0	1.4
	28		6.2	6.4		1.0
50	28	19.6	6.2	13.5	3.1	2.2
	36		10.2	9.5		1.5
63	36	31.2	10.2	21.0	5.0	3.4
	45		15.9	15.3		2.4
80	45	50.2	15.9	34.3	8.0	5.5
	56		24.6	25.6		4.1
100	56	78.5	24.6	53.9	12.6	8.6
	70		38.5	40.0		6.4
125	70	122.7	38.5	84.2	19.6	13.5
	90		63.6	59.1		9.5
160	90	201.0	63.6	137.4	32.2	22.0
	110		95.0	106.0		17.0
200	110	314	95.0	219.0	50.2	35.0
	140		153.9	160.1		25.6
250	140	490.6	153.9	336.8	78.5	53.9
	180		254.3	236.3		37.8
320	180	803.8	254.3	549.5	128.6	87.9
	220		379.9	423.9		67.8
400	220	1256	379.9	876.1	201.0	140.2
	280		615.4	640.6		102.5
500	280	1962.5	615.4	1347.1	314.0	215.5
	360		1017.4	945.1		151.2

It is advisable for the designer to give about 15 to 20% allowance on the theoretical values for frictional and other losses

IPH HYDRAULIC CYLINDER

As per ISO 6020/1 [2007-(E)]

160 BAR Series

Medium Series

[Welded & Bolted Type]

Constructional Details:

❖ **BARREL:**

Made from ST-52/ASTM A-106 Gr. B

Flanges are welded, machined and honed to 0.4 micron finish

❖ **PISTON ROD:**

Made from medium Carbon Steel, ground, hard chrome plated and super finished

❖ **END COVERS:**

Made from Steel; fine machined in CNC Machine.

❖ **GLAND:**

PB Bush inserted for smooth operation of Piston Rod and for suitable guide.

❖ **MOUNTING:**

Various types of mountings are available as per requirement.

❖ **SELF ALIGNING CUSHIONING BOSS:**

Enable accurate movement inside cushioning chamber at the end of the stroke.

❖ **CUSHIONING SCREWS:**

For free adjustment of cushioning movement

❖ **AIR BLEED:**

Screw provided for releasing the trapped air in the Cylinder

❖ **SEALS:**

Piston Seal:

Turcon Glyd Ring for low friction with two Turcite Slyd Rings for guide, as per ISO 7245/1

|| Choice - Polyurethane / Chevron Packing

Gland Seal:

Polyurethane RU3 'U' cup Seal, which has primary and secondary lips for maximum flexibility, as per ISO 5597

|| Choice - Chevron Packing / PTFE

Wiper Seal:

DA 22: Polyurethane Scraper confirms to ISO 6195 type C groove dimensions.

Static Seals:

Nitrile Rubber 'O' Rings.



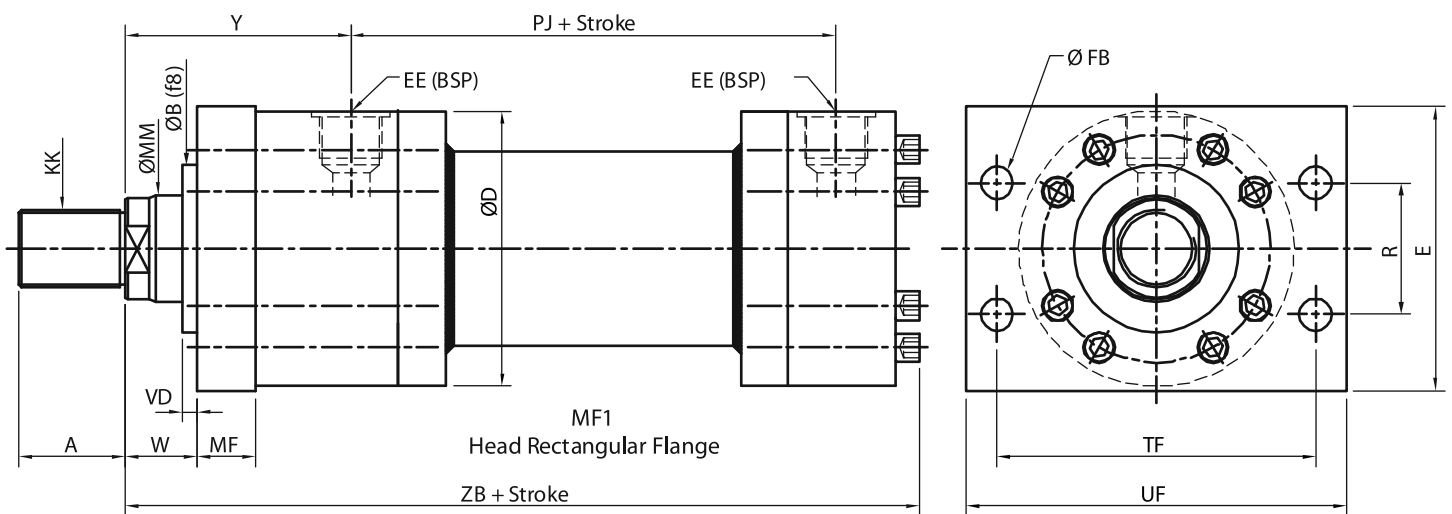
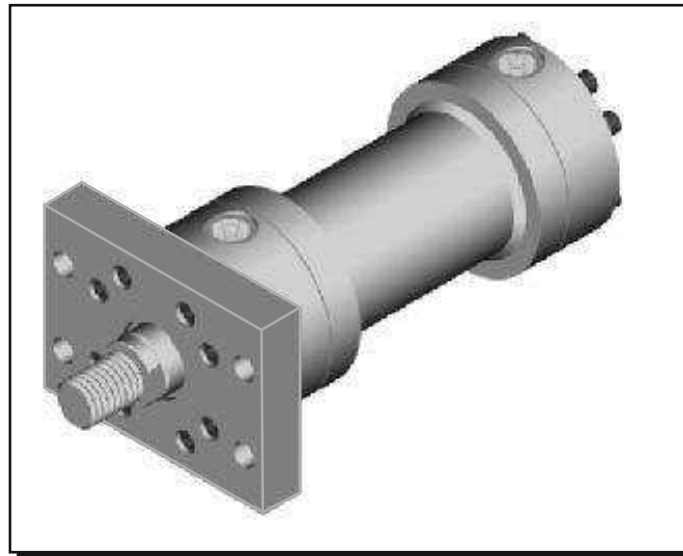

BORE	MM	KK	A	D	B	W	VD	MF	EE	Y	PJ	ZB	TF	UF	R	E	FB
25	16	M12x1.25	16	56	32	16	3	12	1/4"	58	77	158	69.2	85	28.7	60	6.6
	18	M14x1.5	18														
32	18	M14x1.5	18	67	40	16	3	16	3/8"	64	89	178	85	105	35.2	70	9
	22	M16x1.5	22														
40	22	M16x1.5	22	78	50	16	3	16	1/2"	71	97	198	98	115	40.6	80	9
	28	M20x1.5	28														
50	28	M20x1.5	28	95	60	18	4	20	1/2"	72	111	213	116.4	140	48.2	100	11
	36	M27x2	36														
63	36	M27x2	36	116	70	20	4	25	3/4"	82	117	234	134	160	55.5	120	13.5
	45	M33x2	45														
80	45	M33x2	45	130	85	22	4	32	3/4"	91	134	260	152.5	185	63.1	135	17.5
	56	M42x2	56														
100	56	M42x2	56	158	106	25	5	32	1"	108	162	310	184.8	225	76.5	160	22
	70	M48x2	63														
125	70	M48x2	63	192	132	28	5	32	1"	121	174	335	217.1	255	90.2	195	22
	90	M64x3	85														

Note:- All above dimensions are in mm unless specified. Dimensions applicable for strokes upto 1500mm only. Please contact us for longer strokes.

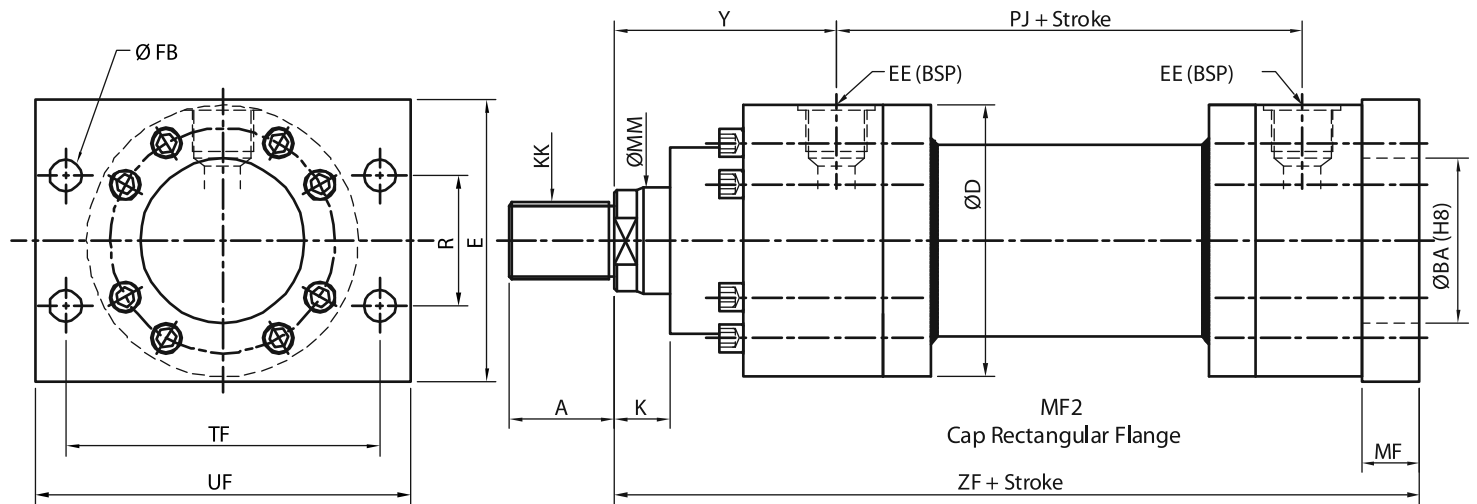

BORE	MM	KK	A	D	BA	K	MF	EE	Y	PJ	ZF	TF	UF	R	E	FB
25	16	M12x1.25	16	56	32	13	12	1/4"	58	77	162	69.2	85	28.7	60	6.6
	18	M14x1.5	18													
32	18	M14x1.5	18	67	40	13	16	3/8"	64	89	186	85	105	35.2	70	9
	22	M16x1.5	22													
40	22	M16x1.5	22	78	50	13	16	1/2"	71	97	206	98	115	40.6	80	9
	28	M20x1.5	28													
50	28	M20x1.5	28	95	60	14	20	1/2"	72	111	225	116.4	140	48.2	100	11
	36	M27x2	36													
63	36	M27x2	36	116	70	16	25	3/4"	82	117	249	134	160	55.5	120	13.5
	45	M33x2	45													
80	45	M33x2	45	130	85	18	32	3/4"	91	134	282	152.5	185	63.1	135	17.5
	56	M42x2	56													
100	56	M42x2	56	158	106	20	32	1"	108	162	332	184.8	225	76.5	160	22
	70	M48x2	63													
125	70	M48x2	63	192	132	23	32	1"	121	174	357	217.1	255	90.2	195	22
	90	M64x3	85													

Note:- All above dimensions are in mm unless specified. Dimensions applicable for strokes upto 1500mm only. Please contact us for longer strokes.

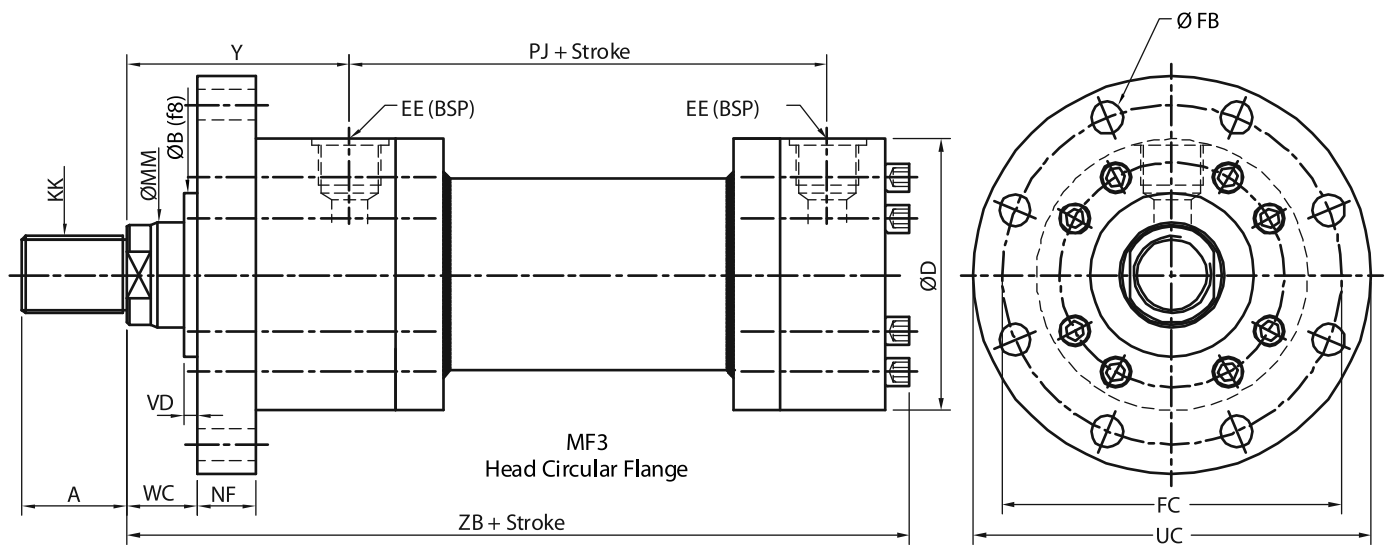
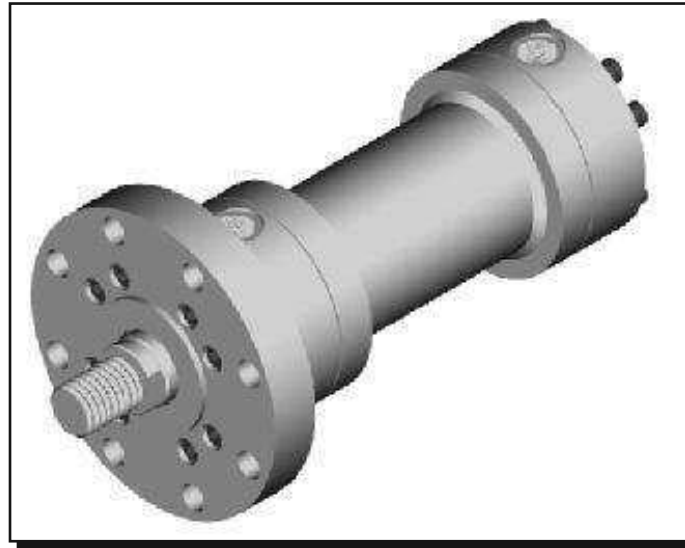

BORE	MM	KK	A	D	B	EE	Y	PJ	ZB	NF	WC	FB	FC	UC	VD
25	16	M12x1.25	16	56	32	1/4"	58	77	158	12	16	Ø6.6x8	75	90	3
	18	M14x1.5	18												
32	18	M14x1.5	18	67	40	3/8"	64	89	178	16	16	Ø9x8	92	110	3
	22	M16x1.5	22												
40	22	M16x1.5	22	78	50	1/2"	71	97	198	16	16	Ø9x8	106	125	3
	28	M20x1.5	28												
50	28	M20x1.5	28	95	60	1/2"	72	111	213	20	18	Ø11x8	126	150	4
	36	M27x2	36												
63	36	M27x2	36	116	70	3/4"	82	117	234	25	20	Ø13.5x8	145	170	4
	45	M33x2	45												
80	45	M33x2	45	130	85	3/4"	91	134	260	32	22	Ø17.5x8	165	195	4
	56	M42x2	56												
100	56	M42x2	56	158	106	1"	108	162	310	32	25	Ø22x8	200	240	5
	70	M48x2	63												
125	70	M48x2	63	192	132	1"	121	174	335	32	28	Ø22x8	235	275	5
	90	M64x3	85												
160	90	M64x3	85	238	160	1 1/4"	143	191	380	36	30	Ø22x8	280	320	5
	110	M80x3	95												
200	110	M80x3	95	285	200	1 1/4"	190	224	480	40	35	Ø26x8	340	385	5
	140	M100x3	112												
250	140	M100x3	112	365	250	1 1/2"	205	290	580	56	40	Ø33x8	420	490	8
	180	M125x4	125												
320	180	M125x4	125	455	320	1 1/2"	250	358	710	63	45	Ø39x8	520	600	8
	220	M160x4	160												
400	220	M160x4	160	565	400	-	-	-	790	80	50	Ø45x8	640	730	10
	280	M200x4	200												
500	280	M200x4	200	645	500	-	-	-	940	100	63	Ø45x12	720	810	10
	360	M250x6	250												

Note:- All above dimensions are in mm unless specified. Dimensions applicable for strokes upto 1500mm only. Please contact us for longer strokes.

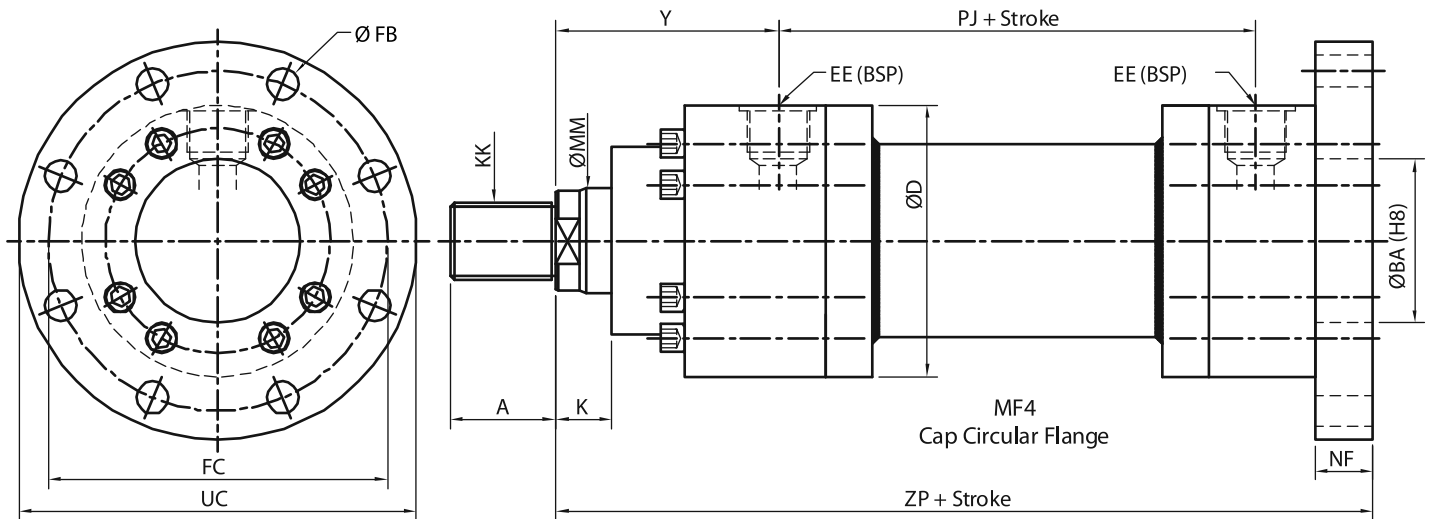
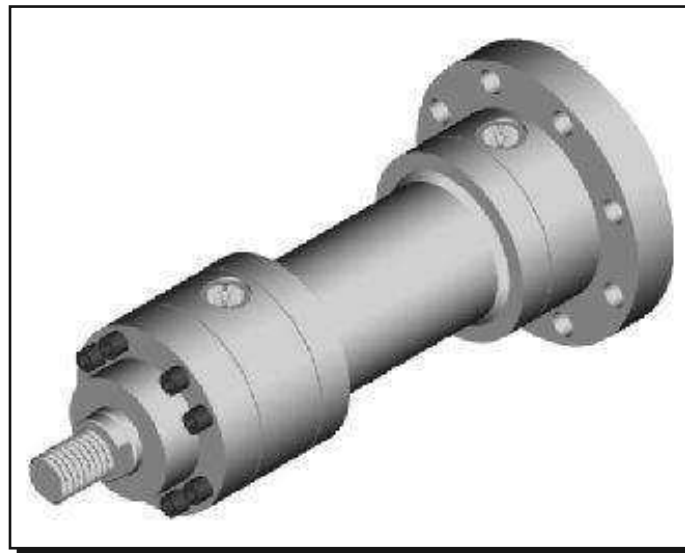

BORE	MM	KK	A	D	BA	EE	Y	PJ	ZP	NF	K	FB	FC	UC
25	16	M12x1.25	16	56	32	1/4"	58	77	162	12	13	Ø6.6x8	75	90
	18	M14x1.5	18											
32	18	M14x1.5	18	67	40	3/8"	64	89	186	16	13	Ø9x8	92	110
	22	M16x1.5	22											
40	22	M16x1.5	22	78	50	1/2"	71	97	206	16	13	Ø9x8	106	125
	28	M20x1.5	28											
50	28	M20x1.5	28	95	60	1/2"	72	111	225	20	14	Ø11x8	126	150
	36	M27x2	36											
63	36	M27x2	36	116	70	3/4"	82	117	249	25	16	Ø13.5x8	145	170
	45	M33x2	45											
80	45	M33x2	45	130	85	3/4"	91	134	282	32	18	Ø17.5x8	165	195
	56	M42x2	56											
100	56	M42x2	56	158	106	1"	108	162	332	32	20	Ø22x8	200	240
	70	M48x2	63											
125	70	M48x2	63	192	132	1"	121	174	357	32	23	Ø22x8	235	275
	90	M64x3	85											
160	90	M64x3	85	238	160	1 1/4"	143	191	406	36	25	Ø22x8	280	320
	110	M80x3	95											
200	110	M80x3	95	285	200	1 1/4"	190	224	490	40	30	Ø26x8	340	385
	140	M100x3	112											
250	140	M100x3	112	365	250	1 1/2"	205	290	606	56	32	Ø33x8	420	490
	180	M125x4	125											
320	180	M125x4	125	455	320	1 1/2"	250	358	723	63	37	Ø39x8	520	600
	220	M160x4	160											
400	220	M160x4	160	565	400	-	-	-	820	80	40	Ø45x8	640	730
	280	M200x4	200											
500	280	M200x4	200	645	500	-	-	-	990	100	53	Ø45x12	720	810
	360	M250x6	250											

Note:- All above dimensions are in mm unless specified. Dimensions applicable for strokes upto 1500mm only. Please contact us for longer strokes.



IPH

MT4

ISO-6020/1

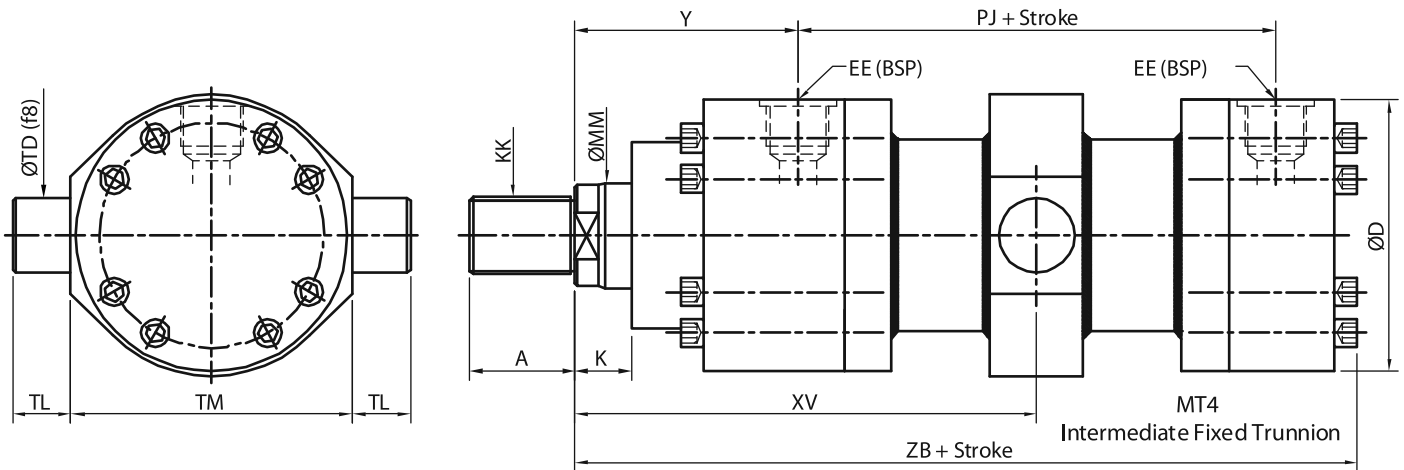

BORE	MM	KK	A	D	K	EE	Y	PJ	ZB	XV	TM	TD	TL
25	16	M12x1.25	16	56	13	1/4"	58	77	158	To Specify	63	12	10
	18	M14x1.5	18								75	16	12
32	18	M14x1.5	18	67	13	3/8"	64	89	178		90	20	16
	22	M16x1.5	22								105	25	20
40	22	M16x1.5	22	78	13	1/2"	71	97	198		120	32	25
	28	M20x1.5	28								135	40	32
50	28	M20x1.5	28	95	14	1/2"	72	111	213		160	50	40
	36	M27x2	36								195	63	50
63	36	M27x2	36	116	16	3/4"	82	117	234		240	80	63
	45	M33x2	45								295	100	80
80	45	M33x2	45	130	18	3/4"	91	134	260		370	125	100
	56	M42x2	56								470	160	125
100	56	M42x2	56	158	20	1"	108	162	310		570	200	160
	70	M48x2	63								700	250	250
125	70	M48x2	63	192	23	1"	121	174	335				
	90	M64x3	85										
160	90	M64x3	85	238	25	1 1/4"	143	191	380				
	110	M80x3	95										
200	110	M80x3	95	285	30	1 1/4"	190	224	480				
	140	M100x3	112										
250	140	M100x3	112	365	32	1 1/2"	205	290	580				
	180	M125x4	125										
320	180	M125x4	125	455	37	1 1/2"	250	358	710				
	220	M160x4	160										
400	220	M160x4	160	565	40	-	-	-	790				
	280	M200x4	200										
500	280	M200x4	200	645	53	-	-	-	940				
	360	M250x6	250										

Note:- All above dimensions are in mm unless specified. Dimensions applicable for strokes upto 1500mm only. Please contact us for longer strokes.

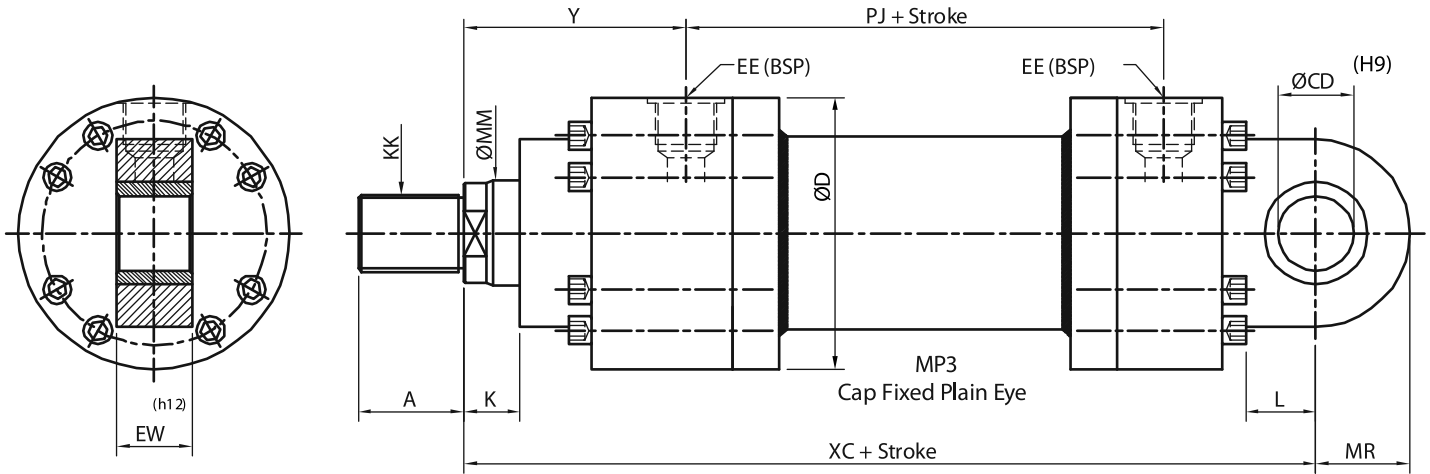

BORE	MM	KK	A	D	K	EE	Y	PJ	XC	CD	EW	L	MR
25	16	M12x1.25	16	56	13	1/4"	58	77	178	12	12	16	16
	18	M14x1.5	18										
32	18	M14x1.5	18	67	13	3/8"	64	89	206	16	16	20	20
	22	M16x1.5	22										
40	22	M16x1.5	22	78	13	1/2"	71	97	231	20	20	25	25
	28	M20x1.5	28										
50	28	M20x1.5	28	95	14	1/2"	72	111	257	25	25	32	32
	36	M27x2	36										
63	36	M27x2	36	116	16	3/4"	82	117	289	32	32	40	40
	45	M33x2	45										
80	45	M33x2	45	130	18	3/4"	91	134	332	40	40	50	50
	56	M42x2	56										
100	56	M42x2	56	158	20	1"	108	162	395	50	50	63	63
	70	M48x2	63										
125	70	M48x2	63	192	23	1"	121	174	428	63	63	71	71
	90	M64x3	85										
160	90	M64x3	85	238	25	1 1/4"	143	191	505	80	80	90	90
	110	M80x3	95										
200	110	M80x3	95	285	30	1 1/4"	190	224	615	100	100	112	112
	140	M100x3	112										
250	140	M100x3	112	365	32	1 1/2"	205	290	773	125	125	160	160
	180	M125x4	125										
320	180	M125x4	125	455	37	1 1/2"	250	358	930	160	160	200	200
	220	M160x4	160										
400	220	M160x4	160	565	40	-	-	-	990	200	200	250	250
	280	M200x4	200										
500	280	M200x4	200	645	53	-	-	-	1210	250	250	320	320
	360	M250x6	250										

Note:- All above dimensions are in mm unless specified. Dimensions applicable for strokes upto 1500mm only. Please contact us for longer strokes.

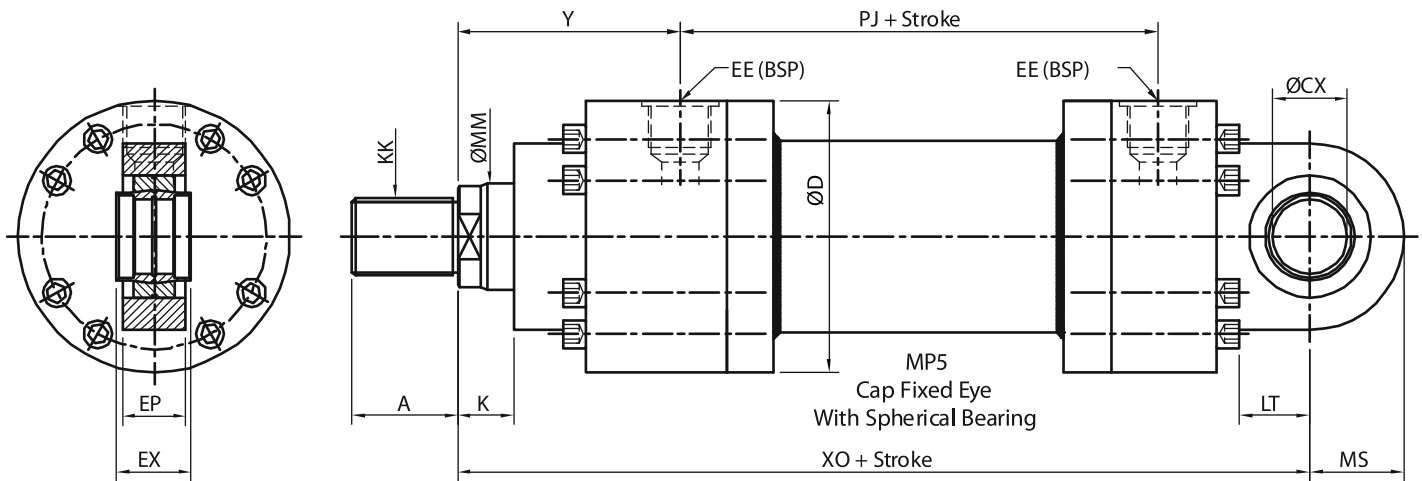

BORE	MM	KK	A	D	K	EE	Y	PJ	XO	CX	EX	LT	MS	EP
25	16	M12x1.25	16	56	13	1/4"	58	77	178	12	12	16	16	10
	18	M14x1.5	18											
32	18	M14x1.5	18	67	13	3/8"	64	89	206	16	16	20	20	14
	22	M16x1.5	22											
40	22	M16x1.5	22	78	13	1/2"	71	97	231	20	20	25	25	18
	28	M20x1.5	28											
50	28	M20x1.5	28	95	14	1/2"	72	111	257	25	25	32	32	22
	36	M27x2	36											
63	36	M27x2	36	116	16	3/4"	82	117	289	32	32	40	40	27
	45	M33x2	45											
80	45	M33x2	45	130	18	3/4"	91	134	332	40	40	50	50	35
	56	M42x2	56											
100	56	M42x2	56	158	20	1"	108	162	395	50	50	63	63	40
	70	M48x2	63											
125	70	M48x2	63	192	23	1"	121	174	428	63	63	71	71	52
	90	M64x3	85											
160	90	M64x3	85	238	25	1 1/4"	143	191	505	80	80	90	90	66
	110	M80x3	95											
200	110	M80x3	95	285	30	1 1/4"	190	224	615	100	100	112	112	84
	140	M100x3	112											
250	140	M100x3	112	365	32	1 1/2"	205	290	773	125	125	160	160	102
	180	M125x4	125											
320	180	M125x4	125	455	37	1 1/2"	250	358	930	160	160	200	200	130
	220	M160x4	160											
400	220	M160x4	160	565	40	-	-	-	990	200	200	250	250	160
	280	M200x4	200											
500	280	M200x4	200	645	53	-	-	-	1210	250	250	320	320	200
	360	M250x6	250											

Note:- All above dimensions are in mm unless specified. Dimensions applicable for strokes upto 1500mm only. Please contact us for longer strokes.

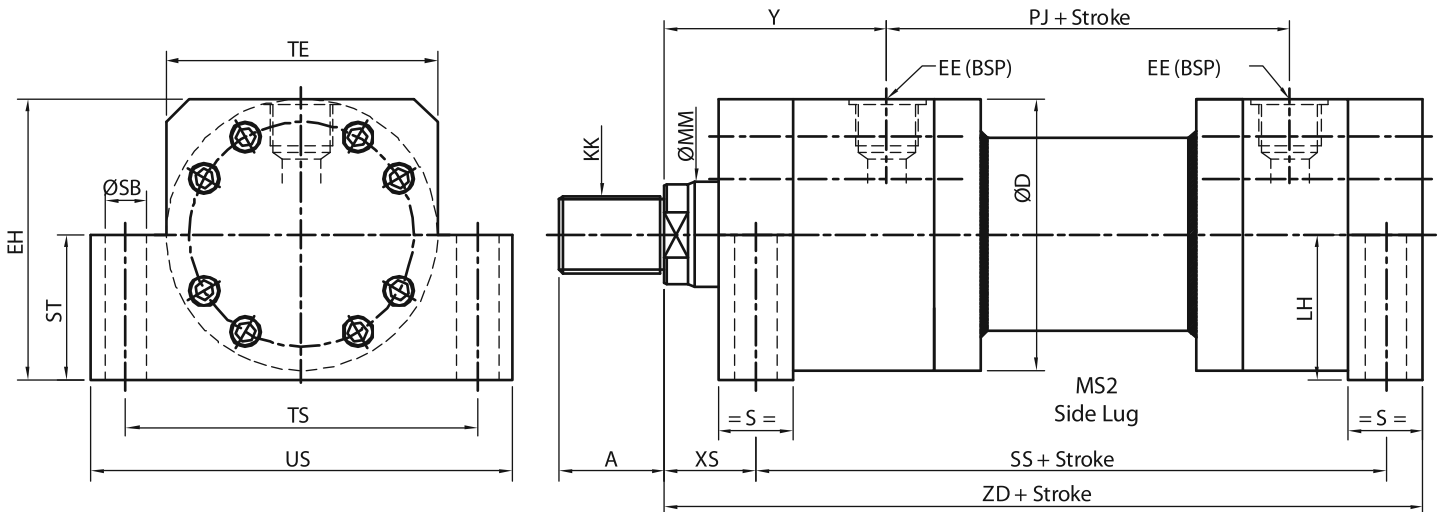
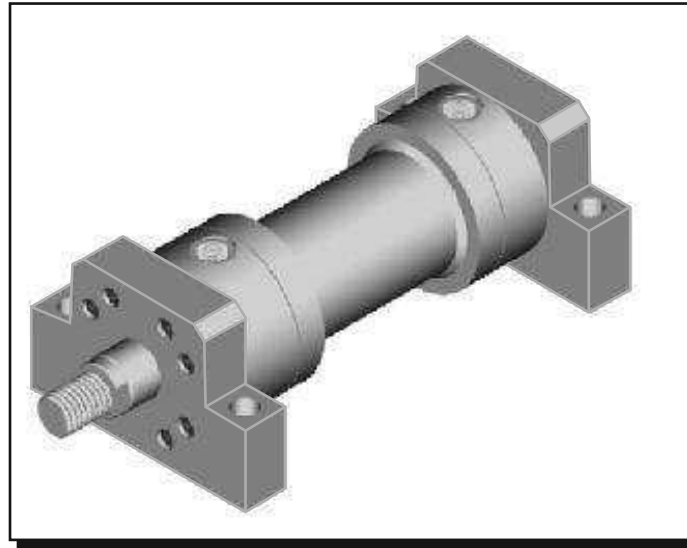

BORE	MM	KK	A	D	TE	EE	Y	PJ	ZD	SS	XS	ST	LH	SB	S	TS	US	EH
25	16	M12x1.25	16	56	56	1/4"	58	77	170	142	18	32	32	9	20	75	92	60
	18	M14x1.5	18															
32	18	M14x1.5	18	67	67	3/8"	64	89	195	163	19.5	38	38	11	25	90	110	72
	22	M16x1.5	22															
40	22	M16x1.5	22	78	78	1/2"	71	97	215	183	19.5	43	43	11	25	110	120	82
	28	M20x1.5	28															
50	28	M20x1.5	28	95	95	1/2"	72	111	237	199	22	52	52	14	32	120	146	100
	36	M27x2	36															
63	36	M27x2	36	116	116	3/4"	82	117	256	211	29	62	62	18	32	150	180	120
	45	M33x2	45															
80	45	M33x2	45	130	130	3/4"	91	134	290	236	34	70	70	22	40	170	210	135
	56	M42x2	56															
100	56	M42x2	56	158	158	1"	108	162	350	293	32	82	82	26	50	205	250	161
	70	M48x2	63															
125	70	M48x2	63	192	192	1"	121	174	381	321	32	100	100	33	56	245	300	196
	90	M64x3	85															
160	90	M64x3	85	238	238	1 1/4"	143	191	430	364	36	119	119	33	60	295	350	238
	110	M80x3	95															
200	110	M80x3	95	285	285	1 1/4"	190	224	522	447	39	145	145	39	72	350	415	288
	140	M100x3	112															

Note:- All above dimensions are in mm unless specified. Dimensions applicable for strokes upto 1500mm only. Please contact us for longer strokes.

ORDERING DETAILS

Hydraulic Cylinders, rated for Operating Pressure of upto 160 Kg/cm²
Welded Construction
As per ISO 6020 / 1 Medium Series

Please use the following format when Ordering :

IPH-160-HM					
<u>CYLINDER BORE</u>					
	<u>PISTON ROD DIA.</u>				
		<u>STROKE</u>			
					<u>CUSHIONING</u>
<u>MOUNTING STYLE</u>					

MF 1 = Head Rectangular Flange

MF 2 = Cap Rectangular Flange

MF 3 = Head Circular Flange

MF 4 = Cap Circular Flange

MP 3 = Cap Fixed Plain Eye

MP 5 = Cap Fixed Eye with Spherical Bearing

MS 2 = Side Lugs

MT 4 = Intermediate Fixed Trunnion

CB = Cushioning at Both Ends

NC = Non Cushioned

CC = Cap End Cushioned

CH = Head End Cushioned

Example: For Hydraulic Cylinder with Bore 100 mm, Piston Rod dia 56 mm, Stroke 500 mm

Mounting Round Front Flange, and Cushioned at both ends will be specified as

IPH - 160 - HM / 100 / 56 / 500 / MF3 / CB

Reference number ISO 6020-1:2007(E)



IPH HYDRAULICS

(formerly Indian Pneumatic & Hydraulic Co)

www.iphindia.in